

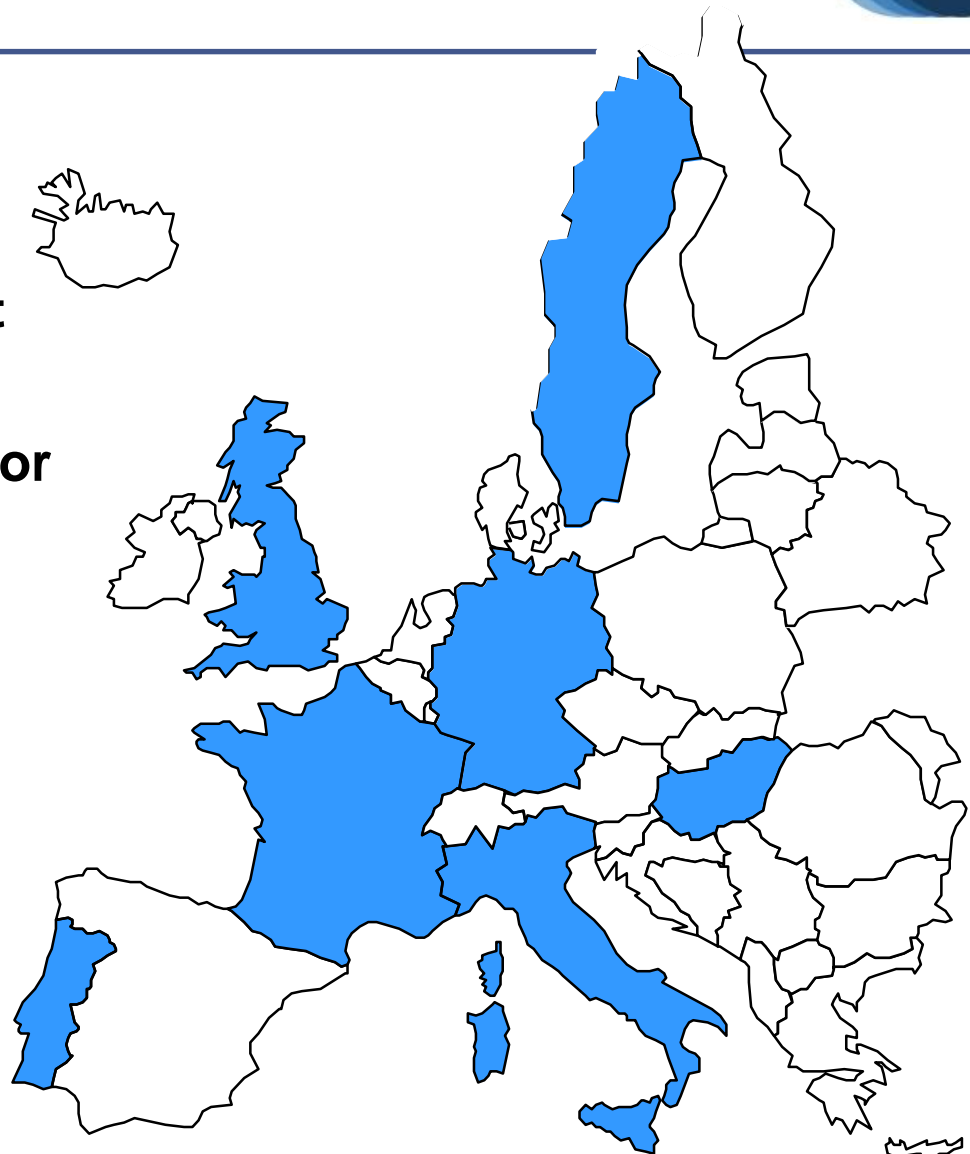

# Fitting the CONCERTO component model approach to AUTOSAR development flow

Stefano Puri  
Intecs S.p.A.  
Pisa, Italy  
[stefano.puri@intecs.it](mailto:stefano.puri@intecs.it)

- 
- CONCERTO methodology and component model
  - CONCERTO and the AUTOSAR process
  - CONCERTO tool support for AUTOSAR



**ARTEMIS JU project**

Call 2012

**Technical Coordinator**

Intecs

**Partners 15**

**Countries 8**

**Start May 2013**

**End April 2016**

**Total cost 9,6 M €**

- “Guaranteed Component Assembly with Round Trip Analysis for Energy Efficient High-integrity Multi-core Systems”- ARTEMIS JU Call 2012
  - Correctness-by-construction for multicore systems through model-driven engineering
  - Enhanced hierarchical, multi-domain component model
  - Support for separation of concerns into the multi-domain, multicore environment
  - Coverage of industrial domains
- Building on the results of the CHES project (ARTEMIS-2008-1-100022)
  - CHES is now a Project under the Eclipse Polarsys Working Group (<https://www.polarsys.org/ches/>)  CHES

*Hereafter we will refer to CHES as component model, methodology and tool, as used and extended by the CONCERTO project*

- Model-driven engineering
  - Models as the central development artifacts
    - CHES Modellig Language
  - Tool assisted automated development
    - Based upon Eclipse, UMLPapyrus
- Component based development
  - Specialized to capture the extra-functional properties of components
    - Real Time
    - Dependability
- Multi-View / Separation of concerns
  - The architectural description of the system is organized into one or more views of the system where each view addresses one or more concerns of the system's stakeholders
    - ISO/IEC/IEEE42010:2011 Systems and software engineering

# The CHESS Modelling Language

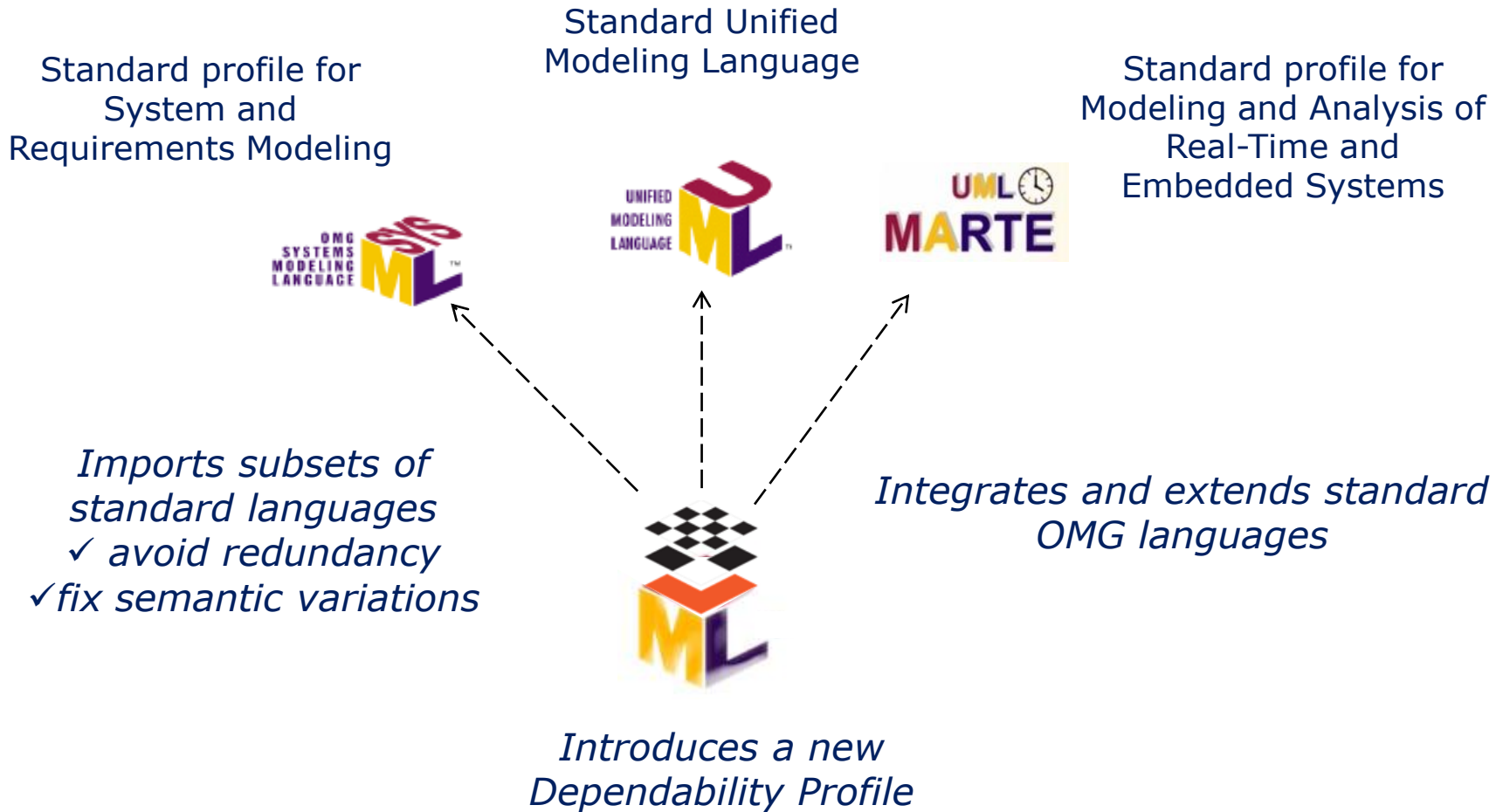

# The CHESSE Component Model

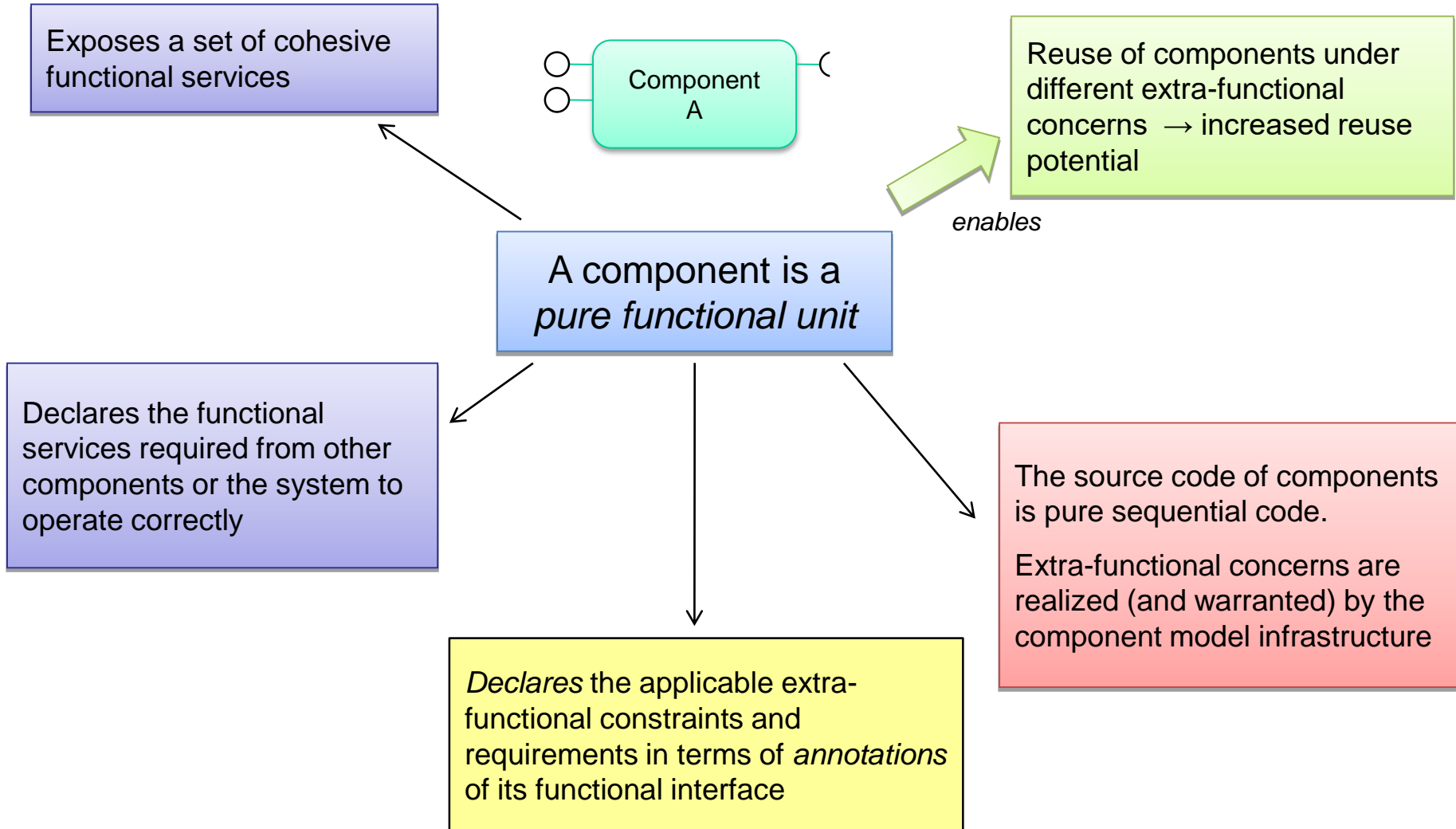

# CHESS Container and Connector

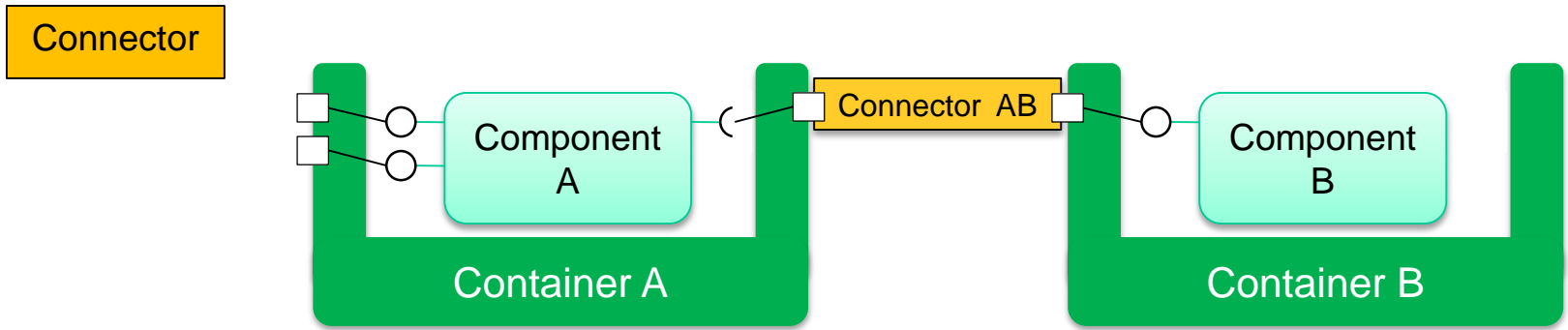
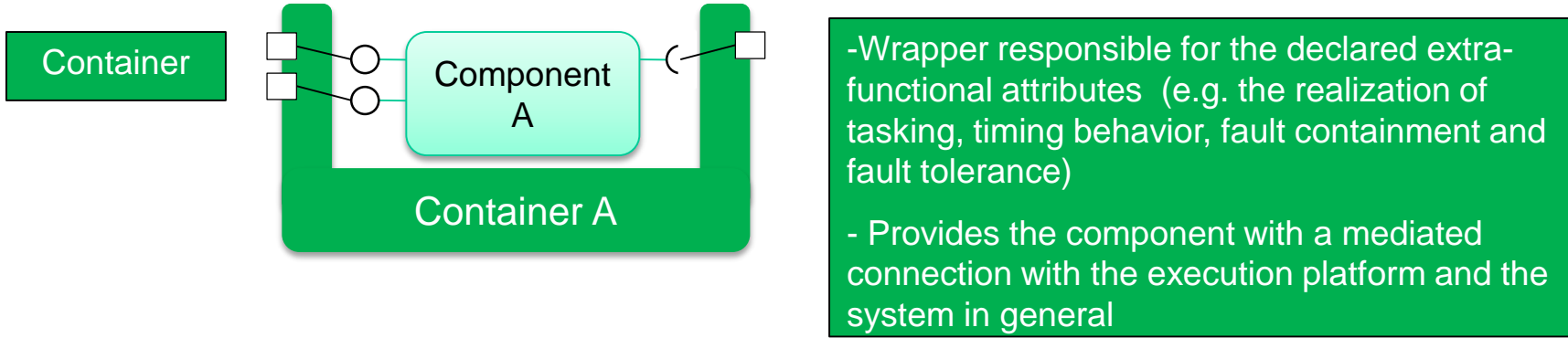

- Addresses interaction concerns
- Decouples the component from the other end-point(s) of a communication
- Realizes connection properties , e.g. procedure/function call, remote message passing ...



# CHESS Design Flow

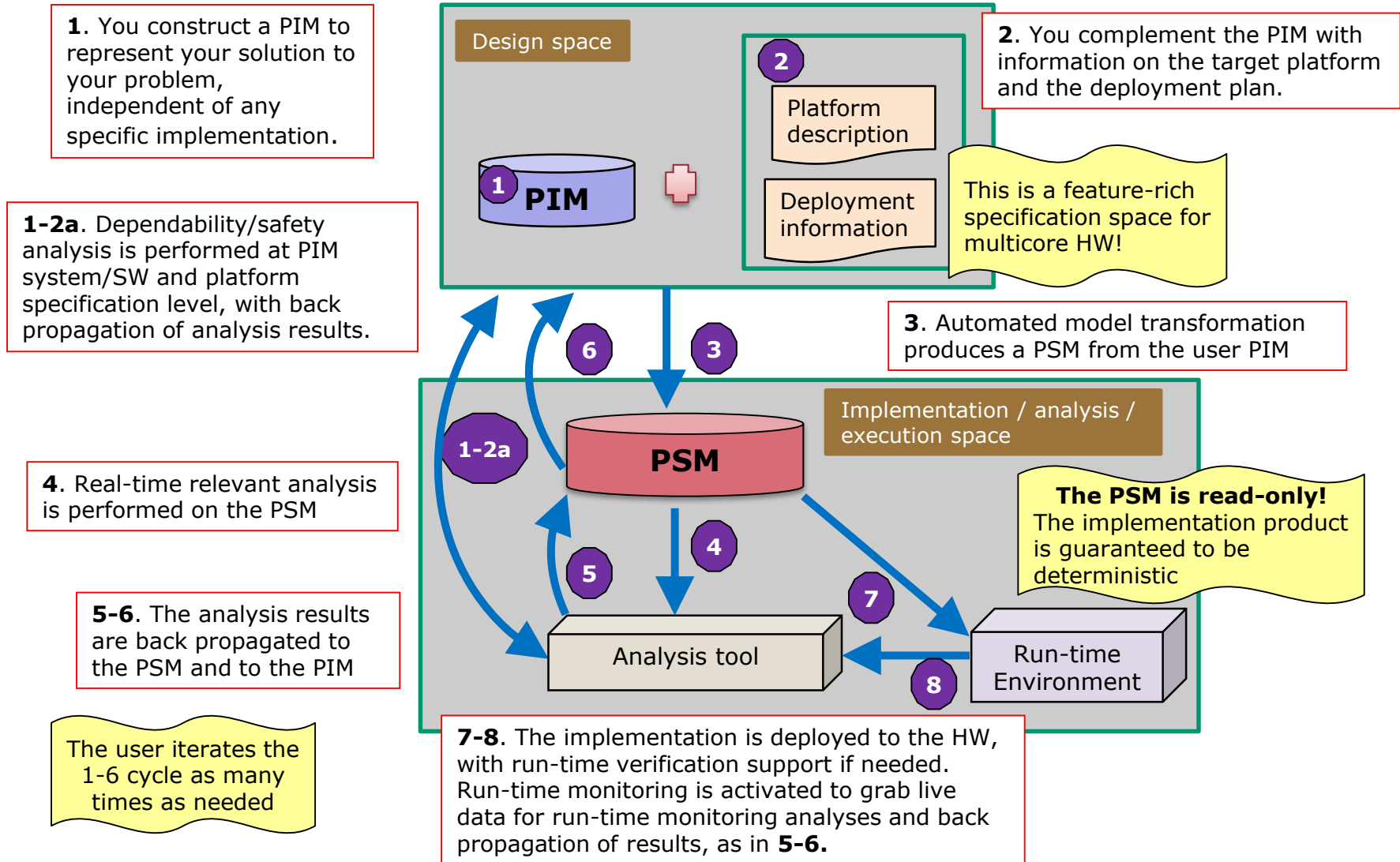

- Cross domain
  - Scheduling and timing analysis for multicore
  - Dependability profile and analysis
    - Failure logic analysis, state based analysis
  - Run-time monitoring
  - Matlab/Simulink Synchronous Block Diagrams (SBDs) support
- Domain specific
  - Avionics
  - Telecare
  - Automotive...



- (AUTomotive Open System ARchitecture)
  - Open and standardized software architecture for automotive, jointly developed by automobile manufacturers, suppliers and tool developers
- Goals:
  - Scalability to different vehicle and platform variants
  - Integration of functional modules from multiple suppliers
  - Maintainability

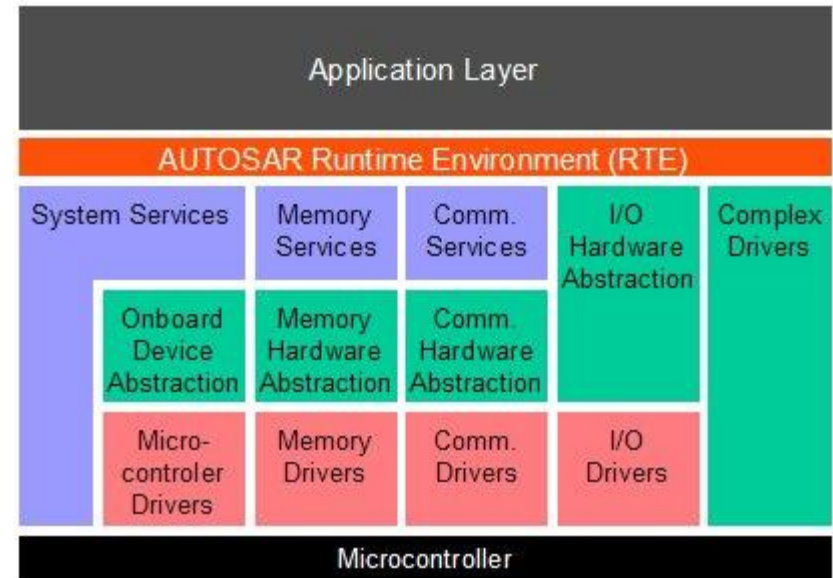

Legend: Basic Software (BSW) Layers



# AUTOSAR methodology steps

- The AUTOSAR methodology comprises the following steps
  - Application Configuration
  - System Configuration
  - ECU specific information extraction
  - ECU Configuration

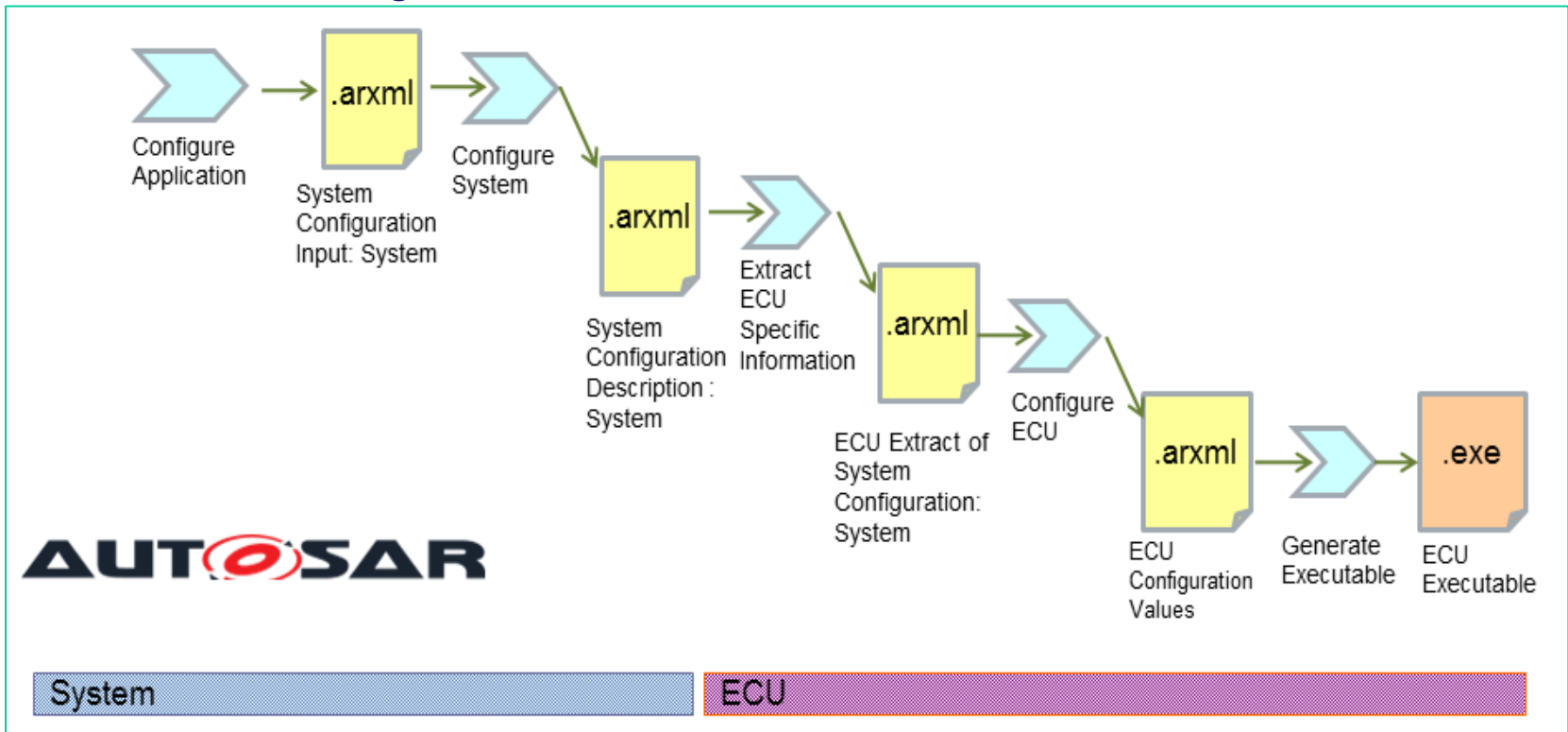

# CHES support for AUTOSAR steps

- The CHES methodology supports the following AUTOSAR steps
  - Application Configuration
  - System Configuration
  - ECU Configuration

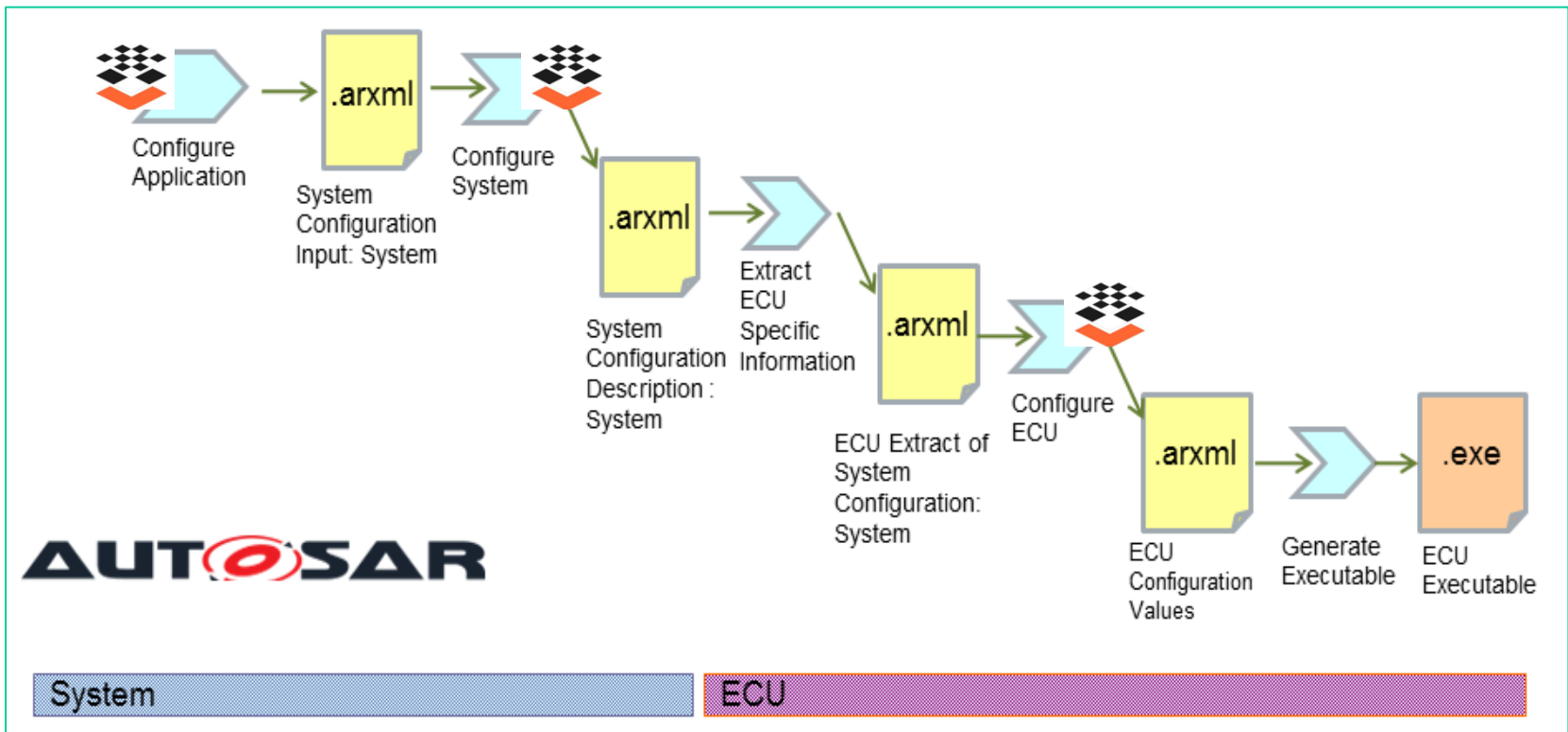

# Modelling the Component-based design with CHES

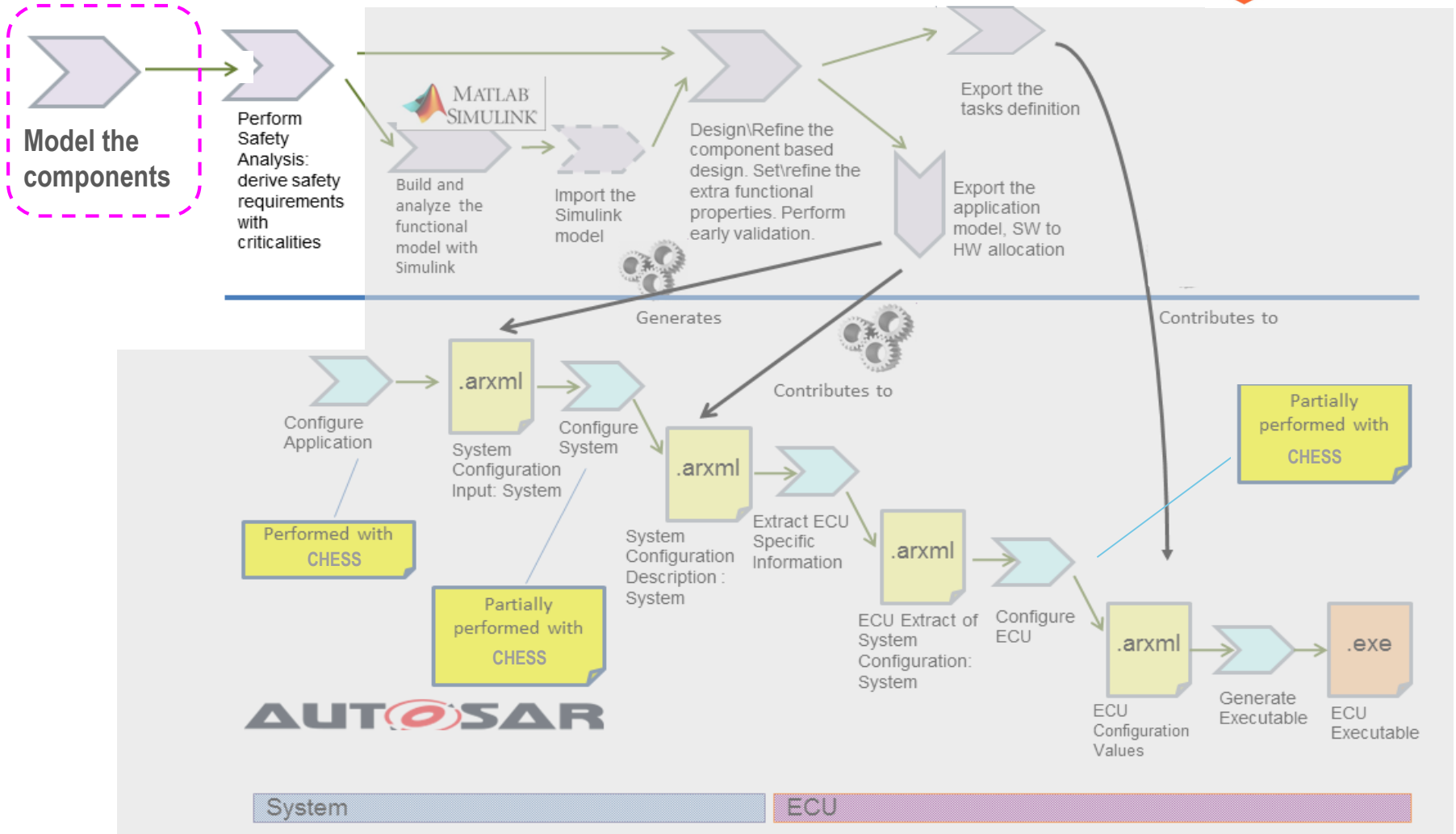

# Modelling the Component-based design with CHES



- Modelling Interfaces, Component Types and Component Implementations

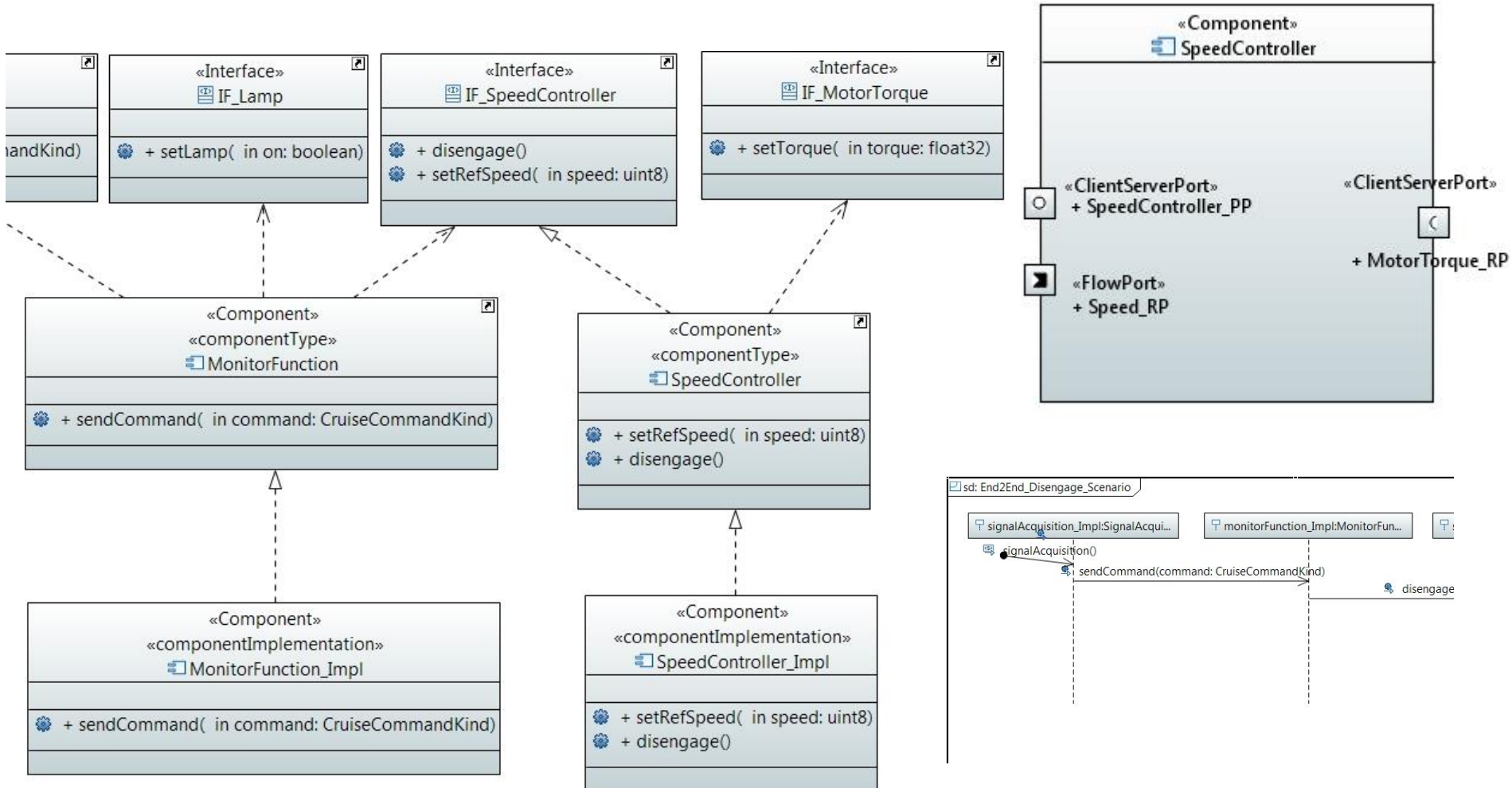

- CHES and AUTOSAR share the definition of software component based design
- Similar fundamentals concepts are available:
  - hierarchical structure
  - ports and interfaces
  - connectors
  - internal behaviour
- Extra concepts available in AUTOSAR (more on this later in the presentation)



# Modelling the Component-based design with CHES (cont'd)

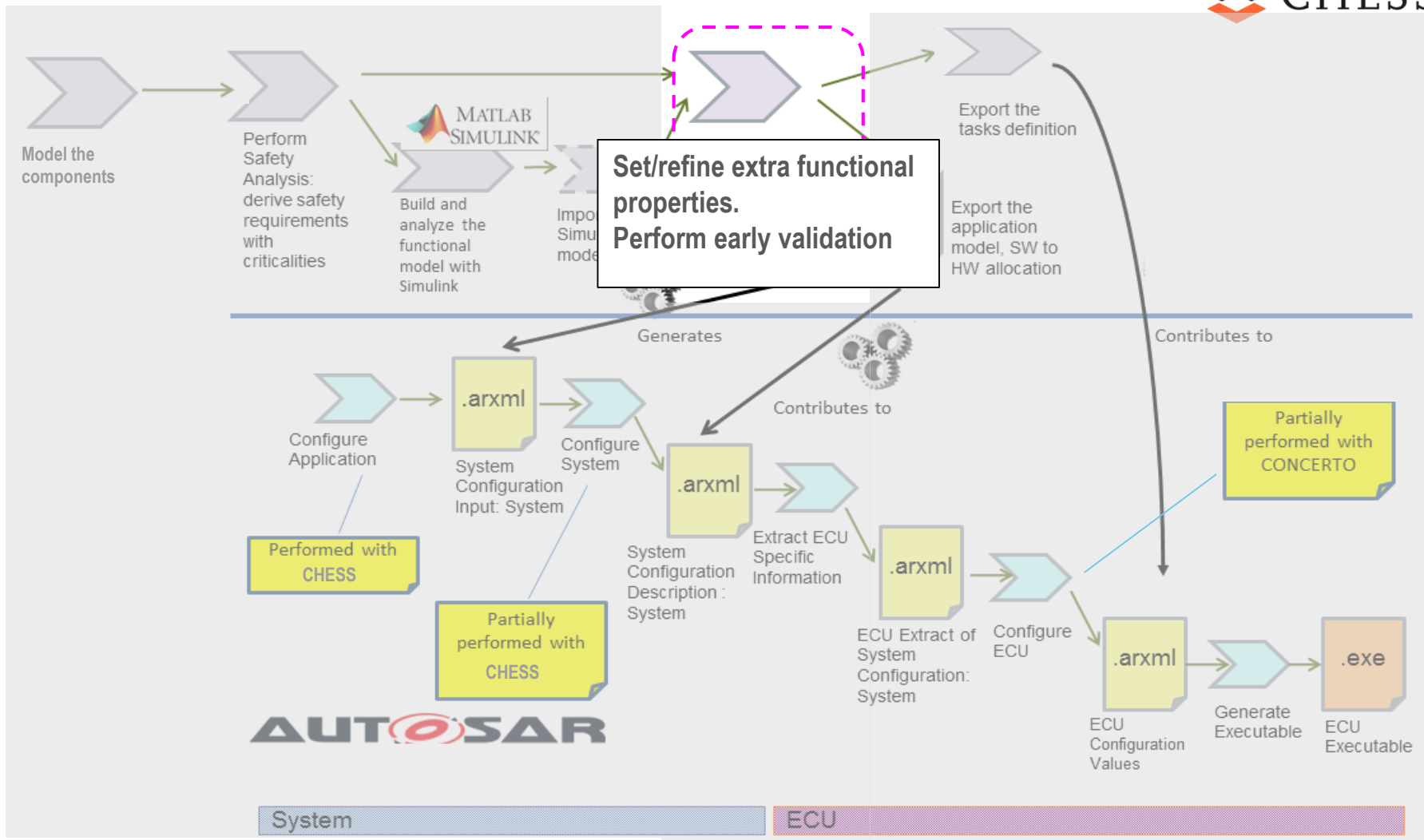



- The CHESS component model allows to perform timing analysis on the model taking into account the timing properties that decorate the components interfaces
  - An extended version of the MAST tool (<http://mast.unican.es/>) is used for timing analysis execution
- This way the modeller can perform early validation on the model and adjust the model until analysis results are satisfactory

# Performing timing analysis with CHESS (2/2)

- Once the extra-functional properties are modelled and the analysis context is set, the CHESS user can perform timing analysis to verify if the system is schedulable

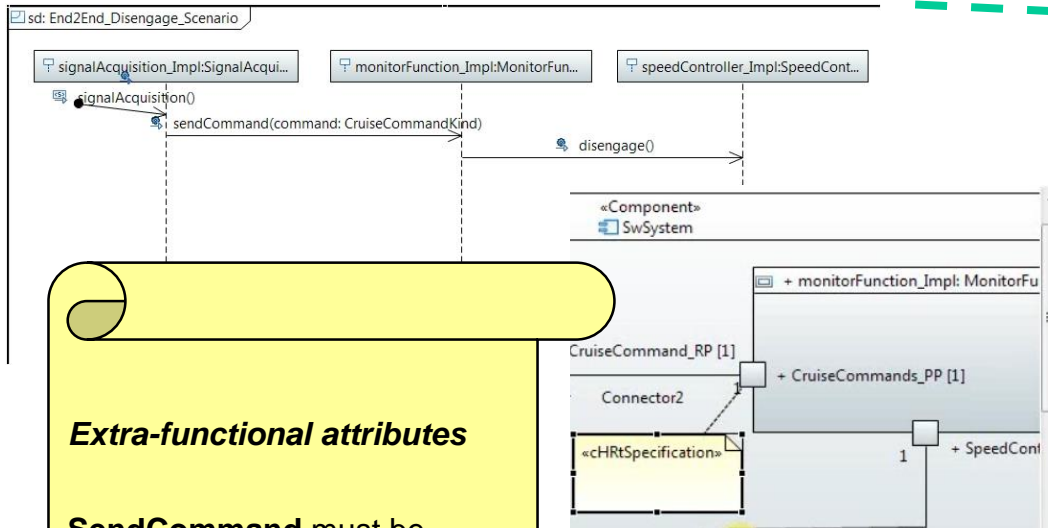

### Extra-functional attributes

**SendCommand** must be executed *sporadically*.

**MIAT**=80ms

**WCET**=25ms

**Deadline** = 80ms

**Response Time** = 70ms

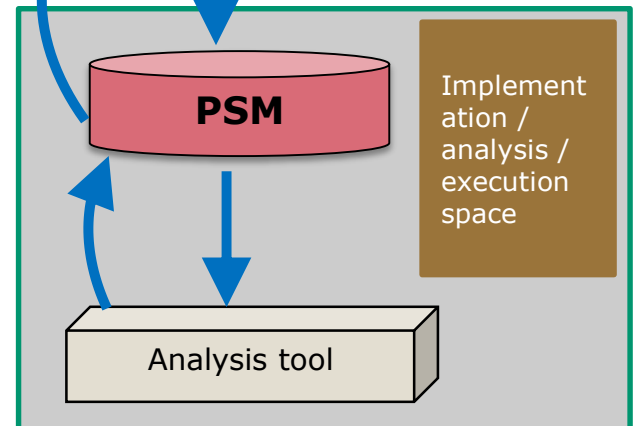
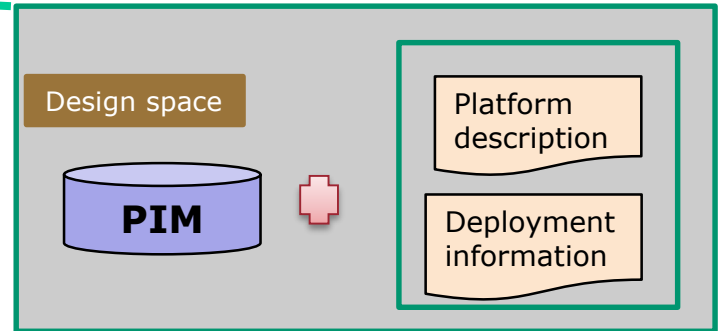

# CHESS input to AUTOSAR process

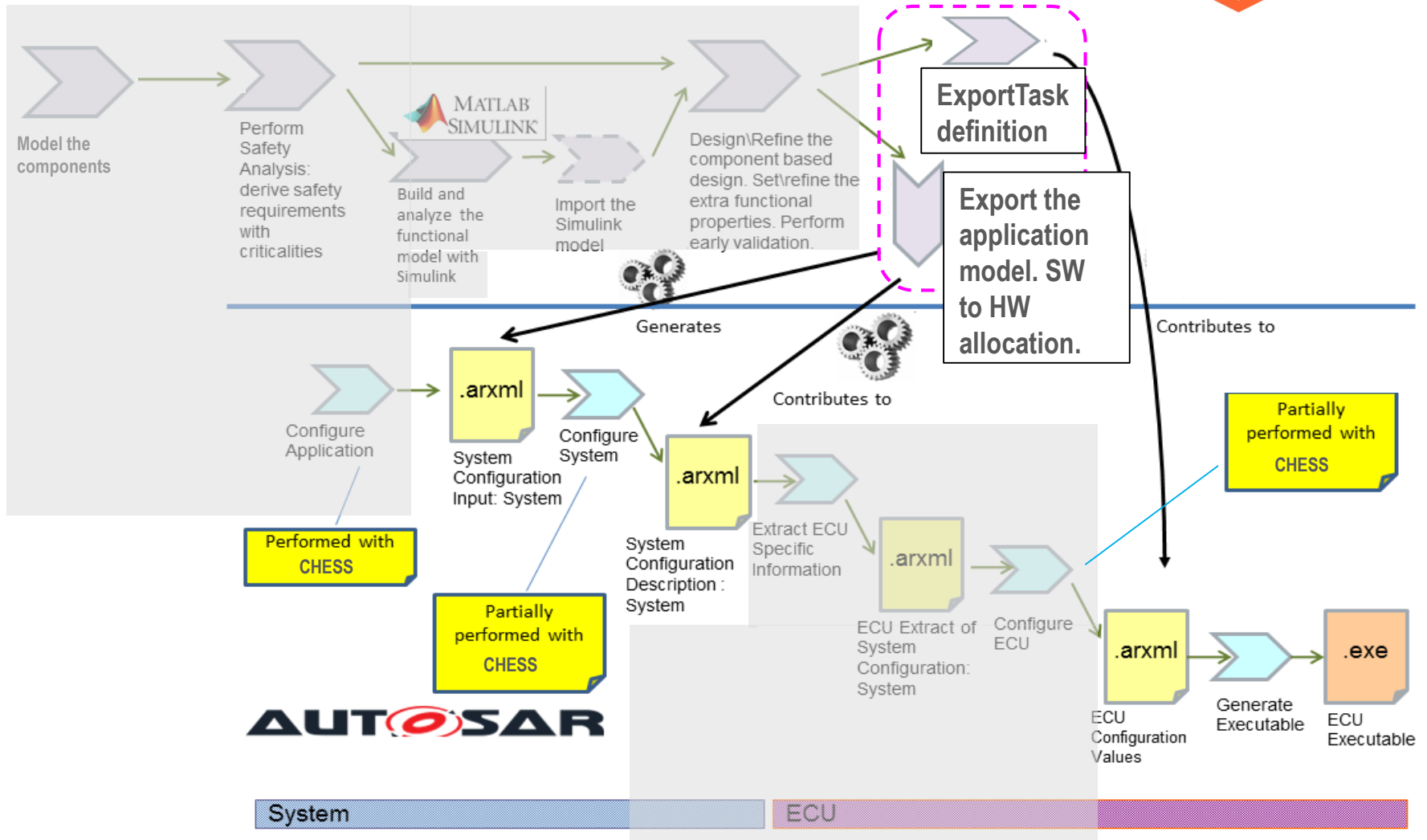

- The CHESSE methodology and toolset allow to sufficiently cover the initial steps of the AUTOSAR methodology
- The automatic generation of the AUTOSAR model starting from the CHESSE one allows easy integration with external AUTOSAR tools
- The extraction of the information about the tasks has to be taken into account to make the added value of CHESSE with respect to the AUTOSAR process and commercial tools stronger
- The AUTOSAR development can benefit from the analysis features of extra-functional properties provided by CHESSE

## Future work

- Evaluate CHES component model extensions
  - Inter-runnable variable: AUTOSAR allows to model variables which are shared by runnables (i.e. functional code) defined in the same component. In particular AUTOSAR allows specifying how runnables can access this shared state such that safe (in the multithreading sense) exchange of data is possible.
    - In CHES access to the shared data could be realized through get/set provided operations, decorated with protected or unprotected access
  - CHES does not allow having data flow between components realized through flow ports; data flow ports are allowed for a given component only to represent the sending/receiving of events to/from the run-time environment. This is however a minor point, given that inter-components data flow can be realized through operation calls
- Improve modelling support for AUTOSAR RTE
  - E.g. to consider the impact of the basic software on the processor utilization and the system scheduling

Thank you for  
your attention!  
Questions?